

ID-20-MF7

Read Only Module

Datasheet



ID Innovations
Advanced Digital Reader Technology
-----Better by Design

Summary

The ID-20-MF7 series contactless card Read only module is based on Mifare reader IC. They come with the choice of internal antenna or external antenna and are suitable and for embedded applications and general Electronic Devices.



Characteristic

- 2 options: internal antenna or external antenna
- ISP(In System Program)function
- Small outline
- Low power consumption

Specification

- Support card :
 - ISO/IEC14443 A/B cards: a) Mifare One S50 b) Mifare One S70 c) MifareUltra Light
 - ISO15693 cards: a) T12K b) I CODE 2 c) Sony Felica
- Model: ID-20MF7-IA (with internal antenna) ID-20-MF7-WA (without internal antenna)
- Frequency: 13.56 MHz
- Read/Write distance: internal antenna --30mm external antenna—up to 80mm
- Fast read/write speed.
- Communication Port: (RS232) TTL / 2400-57600BPS N,8,1
- Power: 5V DC
- Current consumption: <60 mA PK<200MA
- weight: 80g
- Operating temperature: -20°C--- +50 °C
- Storage temperature : -20°C --- +75 °C
- ID-20MF7 model description:
- Certification: CE, C-TICK, ROHS, FCC:

ID-20MF7 model description		Order management	7bytes	4bytes	RS232	WG26	WG3	ABA 2
pin1 and pin 6 connected	pin1 & pin 6 no connection							
read continuously	once reading	Standard version	yes	yes	yes	yes		yes
no reading	once reading	order per required	yes	yes	yes	yes		yes

Dimensions and Pins (bottom view)

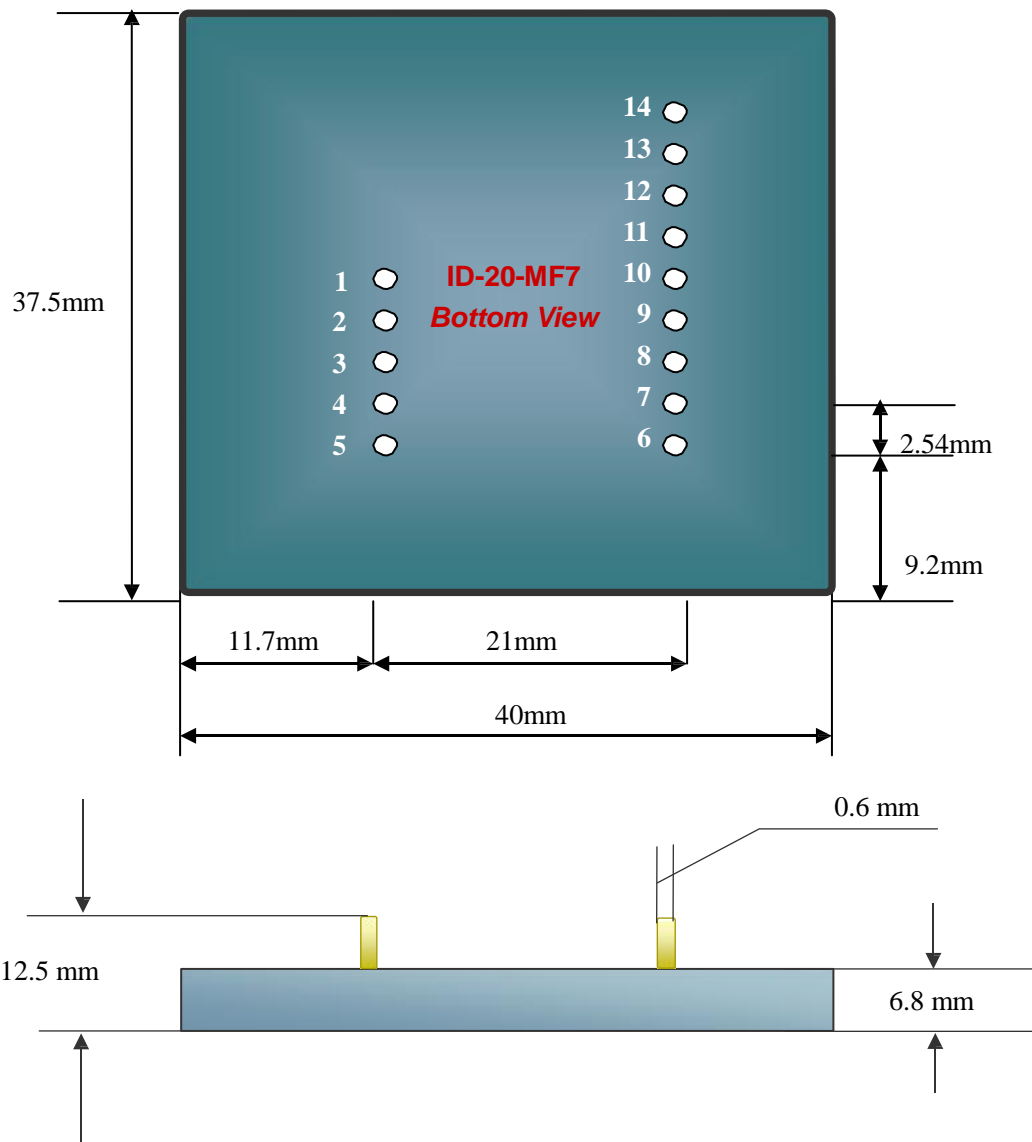

- 1-----GND
- 2-----external antenna TX1
- 3-----external antenna TX2
- 4-----external antenna RX1
- 5-----CP
- 6-----Future
- 7-----+/- (Format Select)
- 8-----D1(Data Pin 1)
- 9-----D0(Data Pin 0)
- 10----LED(LED/BEEPER)
- 11----NC
- 12----RXD
- 13----TXD
- 14----+5V

Circuit Diagram for the ID-20MF7-IA

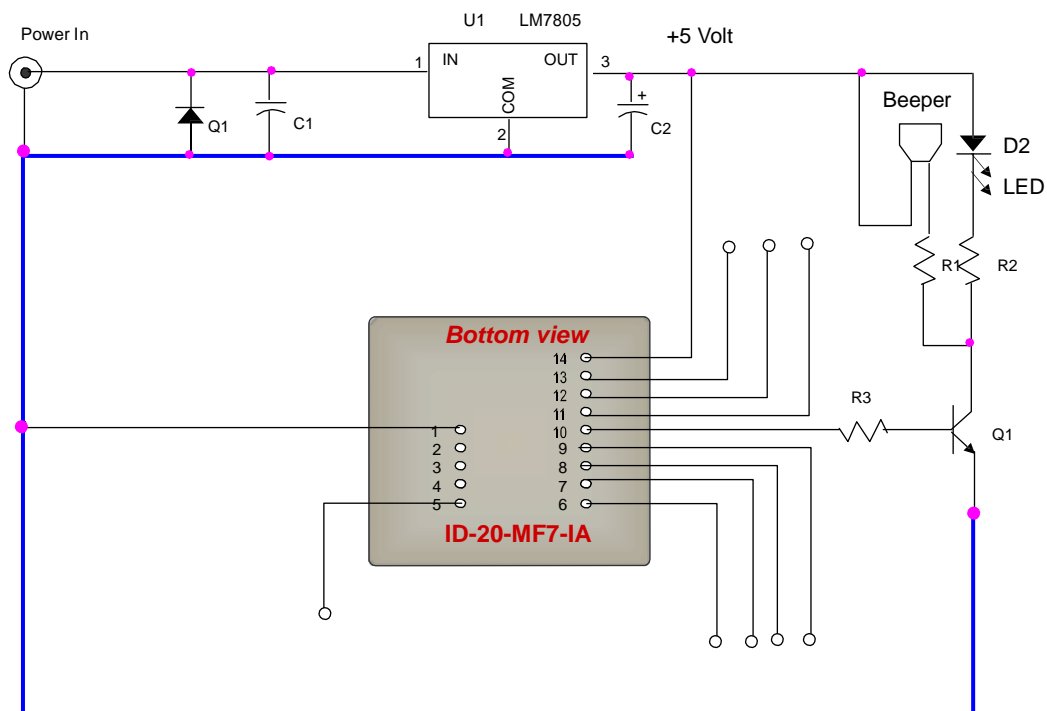

Circuit Diagram for the ID-20MF7-WA

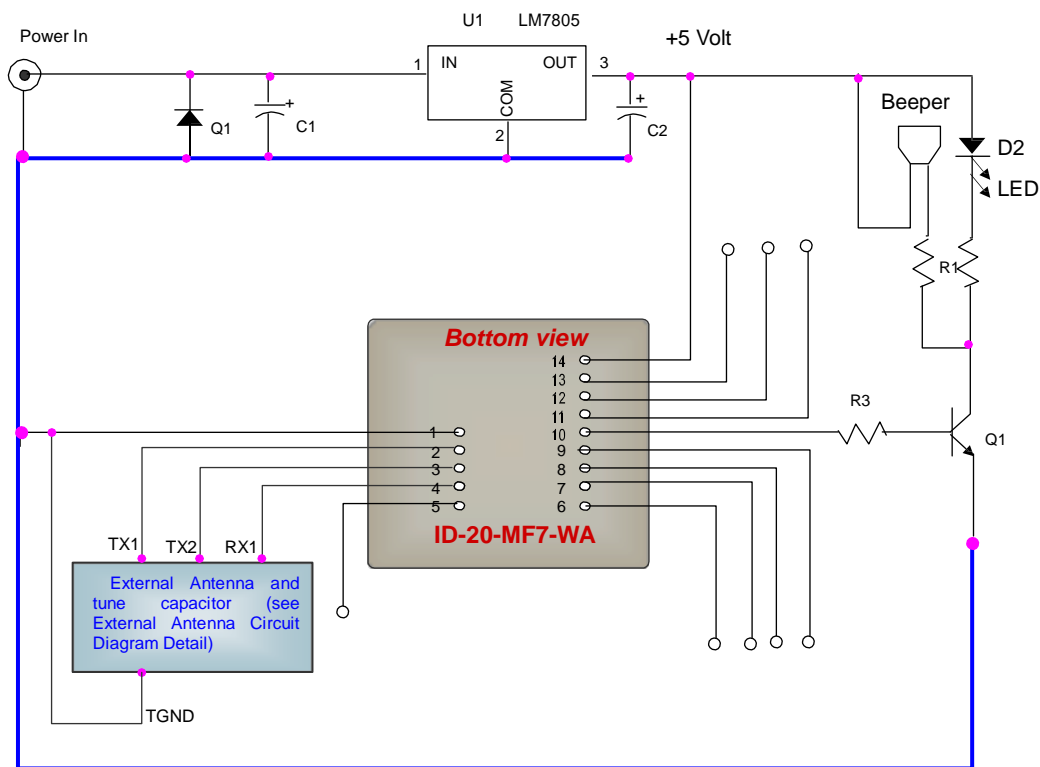

Circuit Diagram for the ID-20MF7 External Antenna

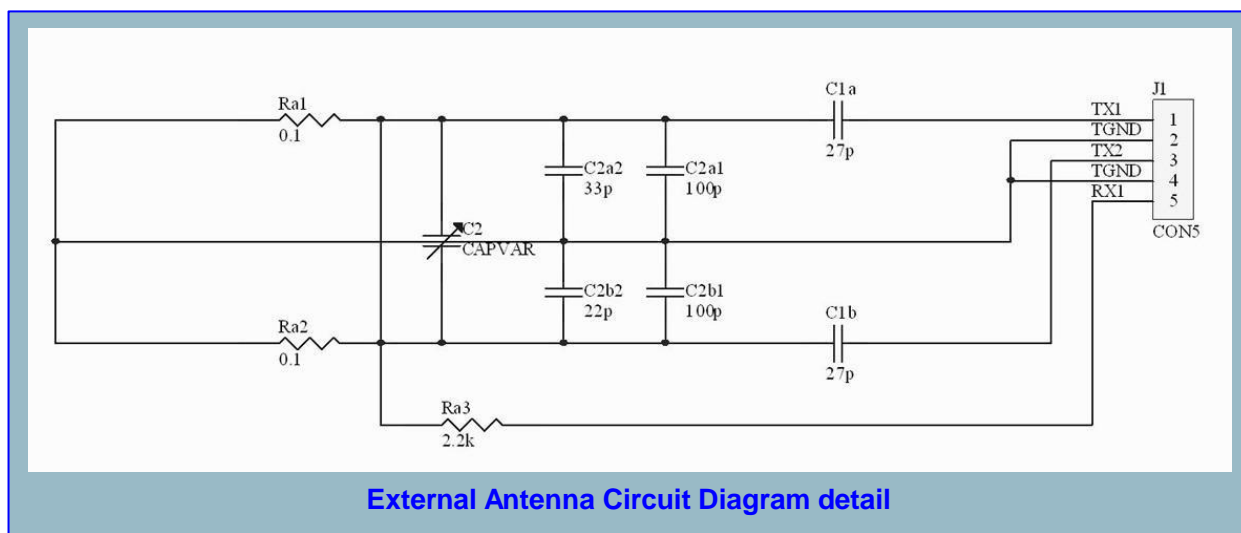

Pin Description & Output Data Formats

Pin.NO	Description	ASCII	Magnet Emulation (optional)	Wiegand26 (optional)
1	Zero Volts and tuning Capacitor Ground	GND 0V	GND 0V	GND 0V
2	To External antenna TX1	To External antenna TX1	To External antenna TX1	To External antenna TX1
3	To External antenna TX2	To External antenna TX2	To External antenna TX2	To External antenna TX2
4	To External antenna RX1	To External antenna RX1	To External antenna RX1	To External antenna RX1
5	Card Present	No function	Card Present	No function
6	Future	Future	Future	Future
7	Format Selector (+/-)	Strap to GND	Strap to Pin 10	Strap to +5V
8	Data 1	No function	Clock	One Output
9	Data 0	No function	Data	Zero Output
10	LED(LED/BEEPER)	Beeper / LED	Beeper / LED	Beeper / LED
11	No Connection	No Connection	No Connection	No Connection
12	RXD	TTL RXD	No function	No function
13	TXD	TTL TXD	No function	No function
14	DC Voltage Supply	+5V	+5V	+5V

Output format:

For a Mifare card with SN: 12 34 AB CD

We name SN0=12 SN1=34 SN2=AB SN3=CD

1 About RS232 output

For RS232 output, the serial data is as below:

02 CD AB 34 12 0D 0A 03

2 About WG26 output

for WG26 output, the serial data is as below:

AB 34 12

3 About ABA output

for ABA output, the serial data is as below:

At first, we'll convert the 4 bytes 16HEX to 5bytes 10hex

then convert the 5 bytes 16DEC to 10bytes ASCII

CDAB3412(HEX)=3450549266(DEC)=33 34 35 30 35 34 39 32 36 36(ASCII)

The final serial data is as below:

0B 33 34 35 30 35 34 39 32 36 36